



e-ISSN:2582-7219



# INTERNATIONAL JOURNAL OF MULTIDISCIPLINARY RESEARCH IN SCIENCE, ENGINEERING AND TECHNOLOGY

Volume 7, Issue 1, April 2024



INTERNATIONAL  
STANDARD  
SERIAL  
NUMBER  
INDIA

Impact Factor: 7.521



6381 907 438



6381 907 438



ijmrset@gmail.com



www.ijmrset.com



# Integrating Electric Vehicles with Battery Management Systems Using Solar Power

Loganathan, Rithika, Youthith, Sowtharya, Mr. T. Kirubhakaran

UG Student, Dept. of EEE., Adithya Institute of Technology, Coimbatore, Tamil Nadu, India

Assistant Professor, Dept. of EEE., Adithya Institute of Technology, Coimbatore, Tamil Nadu, India

**ABSTRACT:** This paper presents a comprehensive approach to integrate electric vehicles (EVs) with Battery Management Systems (BMS) using solar power, aiming to address the growing demand for sustainable transportation solutions. The project focuses on harnessing solar energy to charge EVs efficiently through a robust BMS, thereby reducing reliance on conventional energy sources and minimizing carbon emissions associated with transportation. The paper outlines the project's objectives, methodology, system design considerations, and key components involved. It discusses the solar power integration process, emphasizing charge control mechanisms and voltage regulation techniques to optimize charging efficiency. Furthermore, it highlights the significance of BMS functionality in managing EV battery packs for optimal performance, safety, and longevity. A detailed integration process guide, testing procedures, and performance evaluation results are provided to validate the system's functionality and effectiveness under real-world conditions. Challenges encountered during the project implementation are addressed, along with proposed solutions and strategies for future enhancements.

**KEYWORDS:** Electric Vehicles, Battery Management Systems, Solar Power Integration, Sustainable Transportation, Environmental Impact Assessment.

## I. INTRODUCTION

As the world transitions towards sustainable energy solutions, the convergence of electric vehicles (EVs) and renewable energy sources has emerged as a pivotal avenue in the realm of transportation. One innovative approach in this domain is the integration of EVs with Battery Management Systems (BMS) using solar power. This integration represents a significant step towards enhancing the efficiency, sustainability, and autonomy of electric vehicles while minimizing their environmental footprint. At its core, this integration leverages solar panels to harness the abundant energy from the sun. These solar panels are strategically installed on various surfaces of the EV, such as the roof or hood, to maximize exposure to sunlight. The captured solar energy is then converted into electrical power, which is utilized to charge the EV's battery pack. The BMS ensures optimal charging and discharging of the battery cells, thereby extending their lifespan and maintaining their efficiency. By interfacing with the solar charging system, the BMS orchestrates the flow of solar-generated electricity into the battery, balancing the demands of charging with the availability of sunlight. Furthermore, the integration of solar power with BMS-equipped EVs promotes energy resilience and reliability. By tapping into a decentralized energy source like solar, EV owners can mitigate the effects of power outages or disruptions in the grid infrastructure. This resilience is crucial for ensuring uninterrupted mobility, especially during emergencies or natural disasters.



## II. BLOCK DIAGRAM

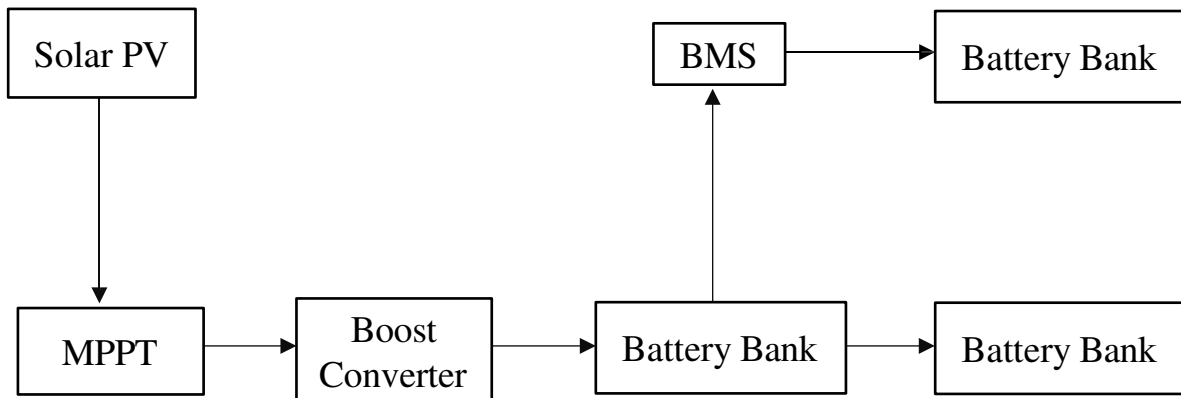

- Solar Panels: The solar panels capture sunlight and convert it into electrical energy.
- Solar Charge Controller: Regulates the voltage and current from the solar panels to ensure optimal charging of the batteries.
- Battery Pack: Stores the electrical energy generated by the solar panels and powers the electric vehicle.
- BMS (Battery Management System): Monitors and manages the battery pack's state of charge (SOC), state of health (SOH), and temperature to ensure safe and efficient operation.
- Battery Balancing Circuit: Balances the charge levels of individual cells within the battery pack to maximize performance and lifespan.
- Electric Vehicle Controller (EVC): Manages the power flow between the battery pack and the electric motor to propel the vehicle.
- Onboard Charger: Charges the battery pack from the solar panels or an external power source when needed.
- Vehicle Control Unit (VCU): Coordinates various vehicle systems, including the electric motor, brakes, and safety features.
- Power Conversion Unit (PCU): Converts the DC power from the battery pack into AC power to drive the electric motor.
- This integrated system ensures efficient utilization of solar energy to charge the EV's battery pack while also providing monitoring and management capabilities through the BMS to optimize performance and prolong battery life.

## III. OUTPUT

### Impact of solar irradiance on the output power of solar panels

Solar irradiance is the amount of solar power received per unit area, which varies based on several influencing factors such as geographic location, time of day, seasonal changes, and atmospheric conditions. The findings reveal that the solar panel output power increases linearly by 47% when the solar irradiance increases from 400 W/m<sup>2</sup> to 1000 W/m<sup>2</sup>. The relationship between solar irradiance and output power demonstrated a linear correlation, with an R<sup>2</sup> value of 0.98393, as depicted. This result underscores the necessity of installing solar panels in locations exposed to the highest irradiance levels.

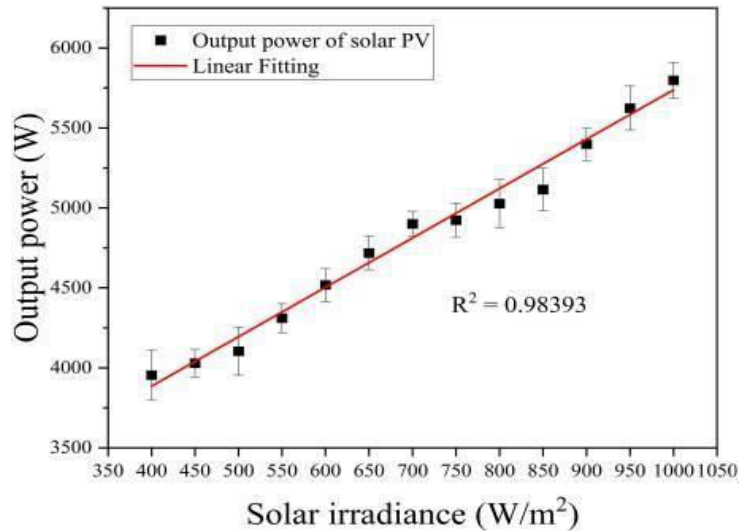

### Energy storage system for EV charging

SOC of energy storage system after capturing energy from the solar panel, the MPPT system channels the power before sending it to the ESS for storage.

Since solar panel output fluctuates due to variations in sunlight intensity, temperature, and other environmental conditions, operating at peak efficiency is impossible. The MPPT rectifies this by continuously monitoring and adjusting the solar panels' voltage and current to perform at the maximum power point.

After optimization by the MPPT, the output power increased to 6.45 kW, a growth of 11.2%, with a solar irradiance of 1000 W/m<sup>2</sup> and solar temperature of 25°C. However, despite this optimization, the SOC of the ESS declined slightly from 100% to 99.86%

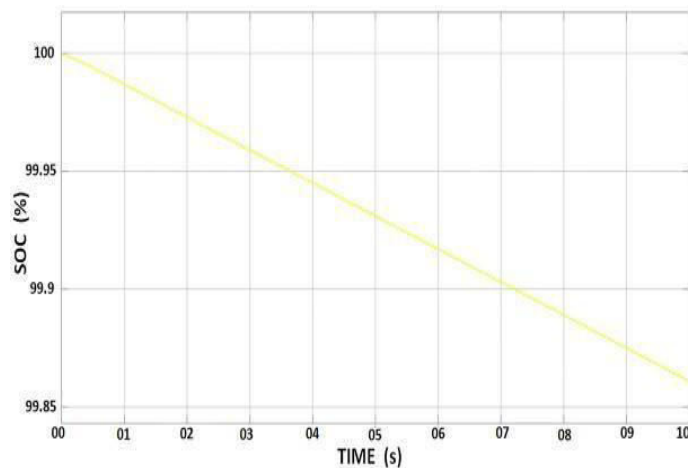

### IV. CONCLUSION

- The BMS ensures efficient charging of the EV's battery pack by managing the flow of solar energy, maximizing the use of renewable energy sources.
- Through continuous monitoring of battery health and temperature, the BMS helps prolong the lifespan of the battery pack, reducing the need for premature replacements and lowering overall maintenance costs.
- The BMS enhances safety by actively monitoring and managing the battery pack's state of charge and temperature, thereby minimizing the risk of overcharging, overheating, and other potential safety hazards.



- By harnessing solar energy to power electric vehicles, the integrated system reduces reliance on fossil fuels and helps lower greenhouse gas emissions, contributing to a cleaner and more sustainable transportation ecosystem.
- Utilizing solar energy for charging can lead to cost savings over time by reducing reliance on grid electricity and minimizing fuel expenses, making electric vehicles more economically attractive for consumers and businesses alike.
- Overall, the integration of a BMS with an EV and a solar charging system represents a holistic approach to sustainable transportation, combining renewable energy sources with advanced battery management technology to create a more efficient, reliable, and environmentally friendly mobility solution.

### REFERENCES

1. Noorollahi Y, Golshanfard A, Aligholian A, Mohammadi-ivatloo B, Nielsen S, Hajinezhad A. Sustainable Energy System Planning for an Industrial Zone by Integrating Electric Vehicles as Energy Storage. *Journal of Energy Storage*. 2020;30: 101553.
2. Booyesen MJ, Abraham CJ, Rix AJ, Ndibatya I. Walking on sunshine: Pairing electric vehicles with solar energy for sustainable informal public transport in Uganda. *Energy Research & Social Science*. 2022;85: 102403.
3. Tahir Y, Khan I, Rahman S, Nadeem MF, Iqbal A, Xu Y, et al. A state-of-the-art review on topologies and control techniques of solid-state transformers for electric vehicle extreme fast charging. *IET Power Electronics*. 2021;14: 1560– 1576.
4. Ma Z, Pesaran A, Gevorgian V, Gwinner D, Kramer W. Energy Storage, Renewable Power Generation, and the Grid: NREL Capabilities Help to Develop and Test Energy-Storage Technologies. *IEEE Electrific Mag*. 2015;3: 30–40.
5. Rodrigues EMG, Godina R, Santos SF, Bizuayehu AW, Contreras J, Catalao JPS. Energy storage systems supporting increased penetration of renewables in islanded systems. *Energy*. 2014;75: 265–280.
6. Sagaria S, Duarte G, Neves D, Baptista P. Photovoltaic integrated electric vehicles: Assessment of synergies between solar energy, vehicle types and usage patterns. *Journal of Cleaner Production*. 2022;348: 131402.
7. Hasan MK, Mahmud M, Ahasan Habib AKM, Motakabber SMA, Islam S. Review of electric vehicle energy storage and management system: Standards, issues, and challenges. *Journal of Energy Storage*. 2021;41: 102940.
8. Habib AKMA Hasan MK Mahmud M Motakabber SMA Ibrahimya MI Islam S. A review: Energy storage system and balancing circuits for electric vehicle application. *IET Power Electronics*. 2021;14: 1–13.
9. Yap KY, Chin HH, Klemeš JJ. Solar Energy-Powered Battery Electric Vehicle charging stations: Current development and future prospect review. *Renewable and Sustainable Energy Reviews*. 2022;169: 112862.
10. Chandra Mouli GR, Bauer P, Zeman M. System design for a solar powered electric vehicle charging station for workplaces. *Applied Energy*. 2016;168: 434– 443.



INTERNATIONAL  
STANDARD  
SERIAL  
NUMBER  
INDIA



# INTERNATIONAL JOURNAL OF MULTIDISCIPLINARY RESEARCH IN SCIENCE, ENGINEERING AND TECHNOLOGY

| Mobile No: +91-6381907438 | Whatsapp: +91-6381907438 | [ijmrset@gmail.com](mailto:ijmrset@gmail.com) |

[www.ijmrset.com](http://www.ijmrset.com)